

INTERNATIONAL RADIO

13620 Tye Road Umpqua, OR 97486

(541) 459-5623 fax (541) 459 5632 E-mail: inrad@rosenet.net www.qth.com/INRAD

FT-1000MP, FT-1000MP MV and FT-1000MP MV Field Roofing Filter Installation Instructions

INTRODUCTION

The MP roofing filter mod consists of a 6 pole, 4 kHz wide filter followed by a high dynamic range, feedback amplifier. The amplifier provides enough gain to override the filter insertion loss plus a dB or two.

The plot below shows the sweep frequency response of the RF board in a Mark V Field radio. The wider curve is the OEM response and the narrow curve is with the Inrad roofing filter mod added. In the Mark V, the most important part of the roofing filter characteristic is from the pass band down about 35 or 40 dB on each side.

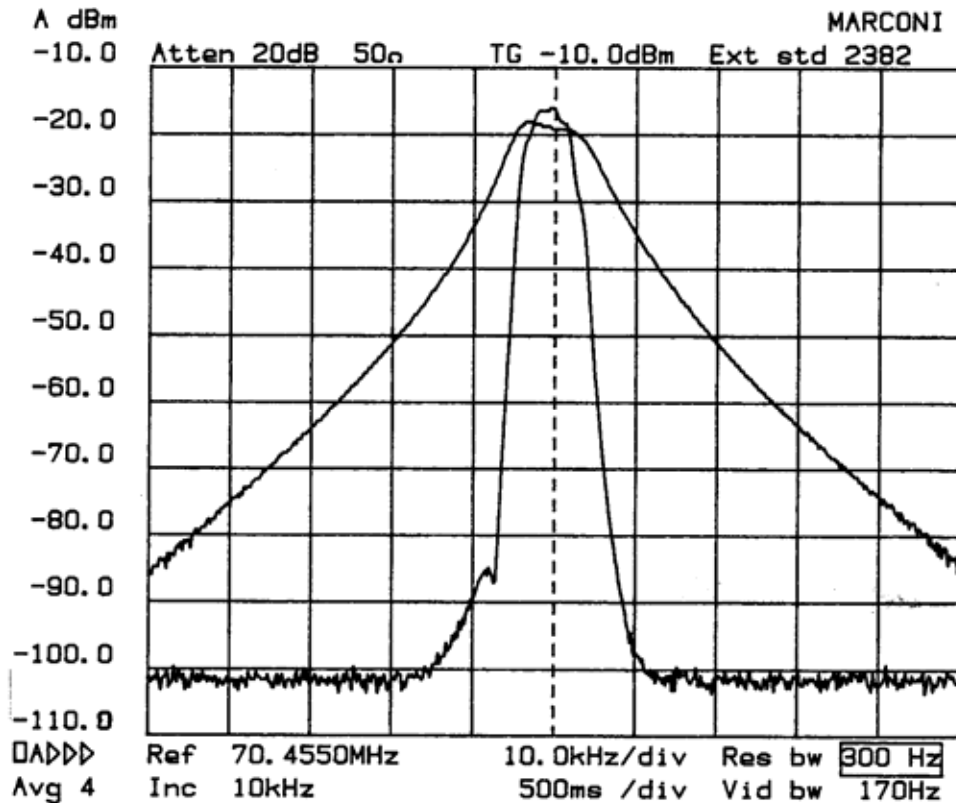

The result of the bandwidth improvement shown above is the reduction of close in intermodulation from multiple signals. The IMD dynamic range will be improved by more than 10 dB for some tone spacings. The blocking dynamic range will be improved by 20 dB or more for some signal spacings. The main

receiver audio response will be reduced about 100 Hz in the SSB mode. Operating the noise blanker will not result in as much degradation of the dynamic range. Adding the bonus mod to the CW audio low pass filter lowers the noise floor by 1 or 2 dB by restricting the internal noise.

1. After installing this mod what will I notice immediately?

Nothing! The mod will have little effect on normal operation of the receiver.

2. What can you expect from this mod?

Less IMD in crowded band conditions, particularly from stations at offset frequencies of 2 to 10 kHz either side of the operating frequency. Less overloading from strong local signals.

3. Will it defeat the noise blanker?

No, the roofing filter is in the circuit before the noise blanker sample is taken. The filter delay is added to both signal and noise. Since less noise and fewer strong signals are able to reach the noise blanker, it actually improves its operation. Less of the “buck shot” effects will be produced.

4. Will this mod allow for wide band SSB, AM and FM reception?

The audio bandwidth of the wider modes will be restricted by the 4 kHz roofing filter in the main receiver. Those modes will still be available for reception with the sub receiver.

A **BONUS** mod is included which reduces the internal hiss and improves the sound of the main receiver audio on CW.

INSTALLATION INSTRUCTIONS

Warning: Modern radios contain components which may be damaged by static discharge. Precautions must be taken to eliminate any static electricity buildup between the operator and the radio before any of the internal circuits are touched. If you are not familiar with the proper techniques for this, consult the Radio Amateurs Handbook.

Note: If you have previously installed the Inrad 70 MHz IF mod you may remove it and install the Roofing filter mod in its place.

- __1. Remove the AC line cord from the transceiver.
- __2. Remove the bottom cover.
- __3. On the Audio Board, locate the outlined area labeled “AF-FIL” in the board quadrant nearest the center of the radio and the rear panel.

- __4. Locate the two holes at diagonally opposite corners of the outlined area.
- __5. Using a nut driver or pliers, press two board mounting standoffs (supplied) into the holes. Use care to not overstress the board. A rocking motion is most effective.
- __6. If your radio is an original MP and not a Mark V, slip the assembled Roofing Filter assembly onto the connectors in the radio and align the standoffs with the board holes. If your radio is a Mark V or Field model, the male connectors have not been installed at the factory. You will need to fashion 2 male pins as shown in the attached sketch.
- __7. Locate the IF cable plugged into J2003 on the left center part of the IF board and pull it out.
- __8. Feed the IF cable under the wires between the IF and Audio boards, and insert it into the coax jack marked J1 on the mod board.

NOTE: Be sure the orientation of the mod is correct. It should plug into the group of **5 pads**, not the group of 6. In some radios this cable may seem to be too short to reach to the Inrad mod connector. Sometimes a gentle tug is all that is needed to extend the cable far enough. If that doesn't work, it will be necessary to remove the top of the radio. Look below the fan near the RF board below at the cable bundle that contains the coax cable we are interested in. It may be necessary to remove the fan to get at it. There is a cable tie which is holding the cable too tightly and it must be cut. This should free up enough cable to reach the Inrad board.

- __9. Insert one end of the cable supplied with the kit into the coax jack marked J2 on the mod board.
- __10. Insert the other end of the supplied cable into J2003 on the IF board.

NOTE: While the radio is still open, you may wish to install the BONUS mod. If you operate CW and like to use the analog detector, this mod will greatly improve the sound of your radio. It does nothing for the other modes or for CW operation with the DSP detector. See below for installation instructions.

- __11. Replace the cover and set the radio right side up. Replace the line cord.
- __12. Hold down FAST and LOCK and turn power on. Press FAST and ENTER and select menu item 9-1.
- __13. If this is a new installation, decrease the setting by 1 integer. If an Inrad 70 MHz IF mod is being replaced, increase the setting by 1 integer. Note that this setting is not critical

BONUS: MAIN RECEIVER AF FILTER MODIFICATION (Thanks, K9AN)

Both the main and the sub receivers have an active low pass filter in the audio chain. These filters are in use when the DSP is off. (Many CW operators prefer to listen with the DSP off.) The pass band of the main receiver is flat with a -3 dB point about 1400 Hz. The sub receiver peaks up about 4 dB at 600 Hz and

has a -3 dB point about 900 Hz. The sub receiver has a substantially lower response to the noise components above 1000Hz, which makes it more pleasing to listen to. The addition of one capacitor to the main receiver low pass filter can provide a similar audio response and cut the high frequency hiss by 10 dB. This makes a substantial improvement in the sound of CW.

To install the bonus capacitor mod, locate C3015 on the audio board central part, nearer the rear panel. Fashion small hooks on the bonus capacitor leads very close to its body. Bend C3015 over gently and hook the bonus capacitor leads over C3015 leads. Solder quickly with a small iron. Use care to not unsolder C3015.

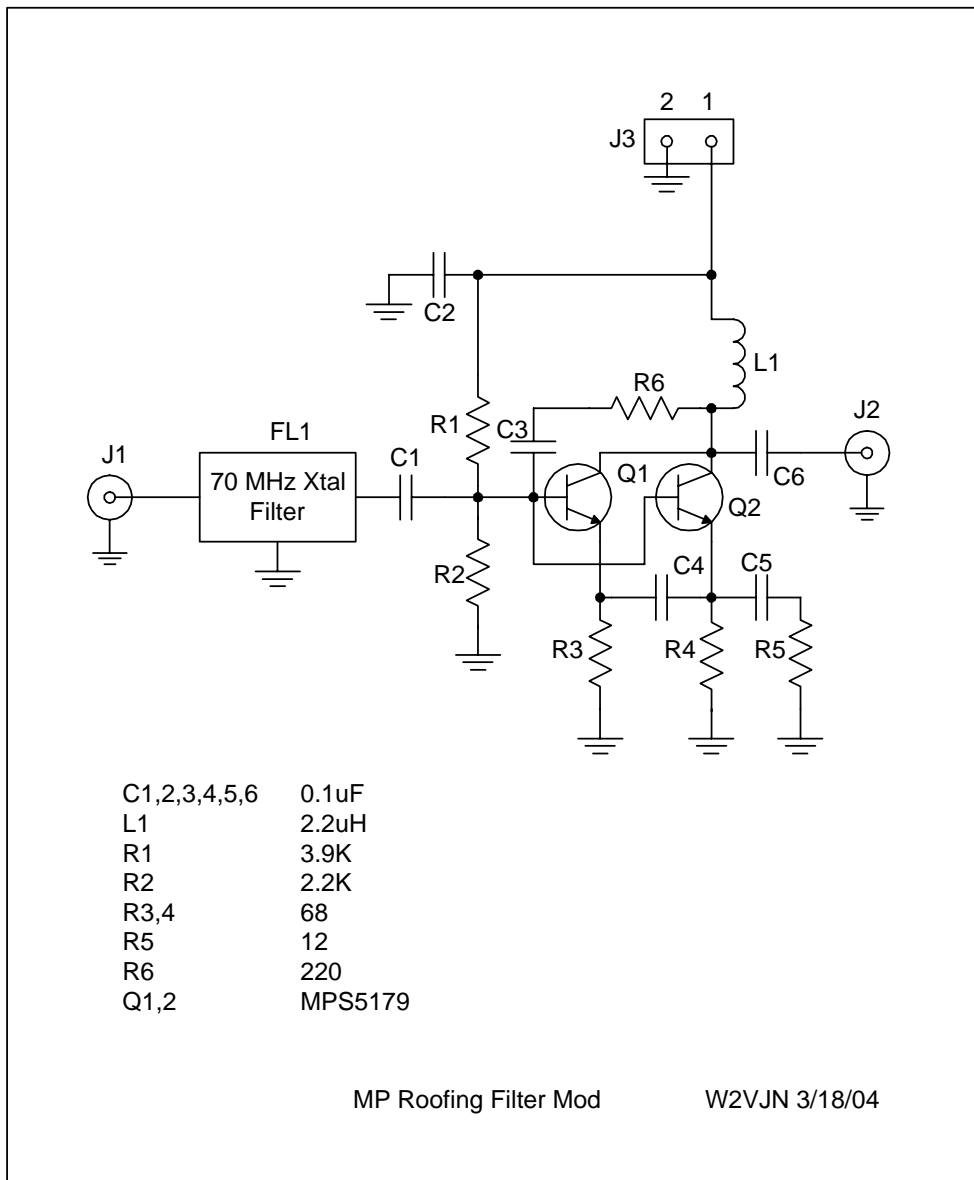

INSTRUCTIONS FOR THE FT-1000MP MARK V AND MARK V FIELD

The male connector used in the FT-1000MP to power the Inrad Roofing filter mod has been left off of the Mark V audio board. In order to power the Inrad mod, two # 22 wires, each about 1 " long, must be inserted into the pad holes as shown.

-These wires should be formed to stand straight and vertical after installation.

-The wire insulation should be removed after soldering.

-Next the plastic board standoffs should be inserted into the holes provided.

-Then the Inrad mod can be lowered in place so the #22 wires go into the proper holes in the mod connector. No soldering is required, as the wires are acting as connector pins.

-After the mod is in place the excess #22 wire should be trimmed off.

Note: Use care that the wires are not pushed too far through the pad holes, as they may contact the chassis and short the +5 volts.

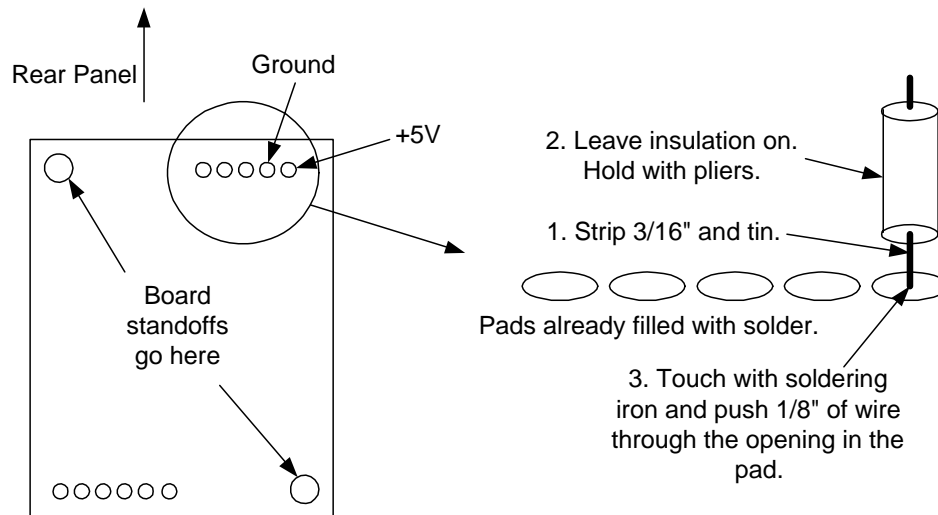

PARTS LIST

Assembled Roofing Filter board (Inrad 115)
Coax cable 8"
Board mounts with nuts
0.047 uF Mylar capacitor
2" #22 insulated solid wire

International Radio © 2005. Modifications done at your own risk; seek help if you are not qualified. International Radio Corp. assumes no responsibility for any damages or injuries resulting from improper installation of this modification kit.

