

RF Sampler for Pre-Distortion Feedback

For the pre-distortion application the radio is working in full-duplex mode. A safe feedback path is necessary to bring samples of the TX signal back to the RX port. To obtain best efficiency of the linearization the ADC should be driven close to full scale level (-15 dBm, ATT=0) and therefore the attenuation of the feedback path has to be adjusted to the power level of the used amplifier. The coupler itself provides a 30 dB coupling attenuation, followed by a 22 dB pad, an additionally selectable 10 dB pad and an adjustable resistive divider. To cover a power range up to 1.5kW the total attenuation is selectable up to ~ - 85 dB. Fine tuning is possible with the 1 dB step attenuator on HERMES etc.

Fig.1 shows the schematic of the 30 dB broadband RF sampler and the variable attenuator section. The sampler has to be inserted into the antenna feeder (J1 towards the antenna) like a SWR bridge. The insertion loss is < 0.15 dB, while the frequency response of the coupling loss is rather flat (± 1 dB), i.e. no new adjustment of the feedback path is necessary when changing bands. The return loss at J1 and J2 is sufficient low (e.g. -18 dB @ 50 MHz).

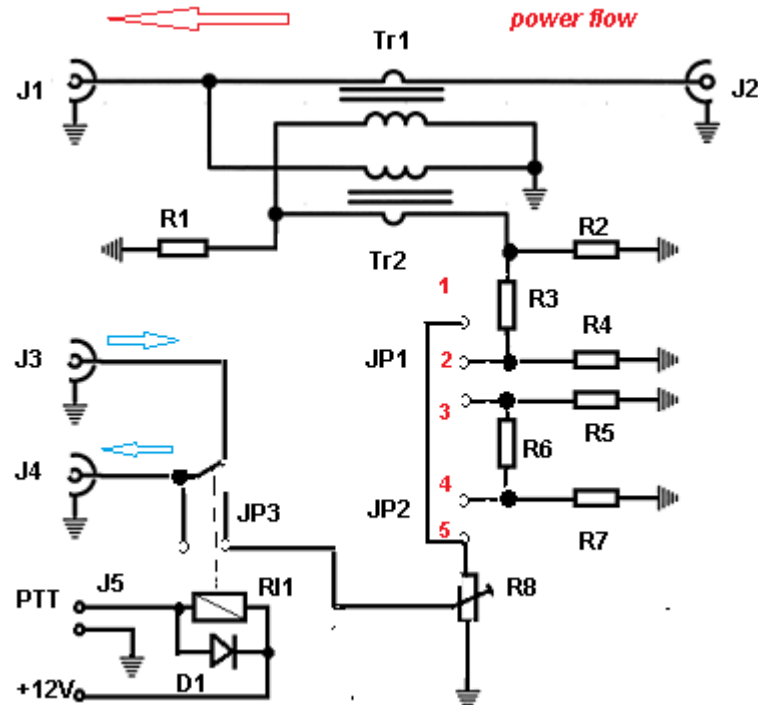

Figure 1 - RF sampler

J3/J4 is looped into the RX path. J4 has to be directly connected to the RX port of HERMES etc., whilst J3 leads to a RX entry of ALEX or another filter bank. During RX mode J3 is connected to J4 via the relay R11. During TX mode the attenuated feedback signal runs via the PTT controlled relay to J4. The relay effectively increases the crosstalk isolation of the antenna switch, what is sometimes necessary especially at higher TX power levels. For individual setups the relay can be bypassed applying a jumper at JP3.

The double side PCB 120 (110/100) x 53 mm – Fig.2 - needs no plated through holes, only a couple of small rivets or wires and can be easily produced as an ‘afternoon project’ by each home-brewer. All components are assembled on the top side like the standard SMDs.

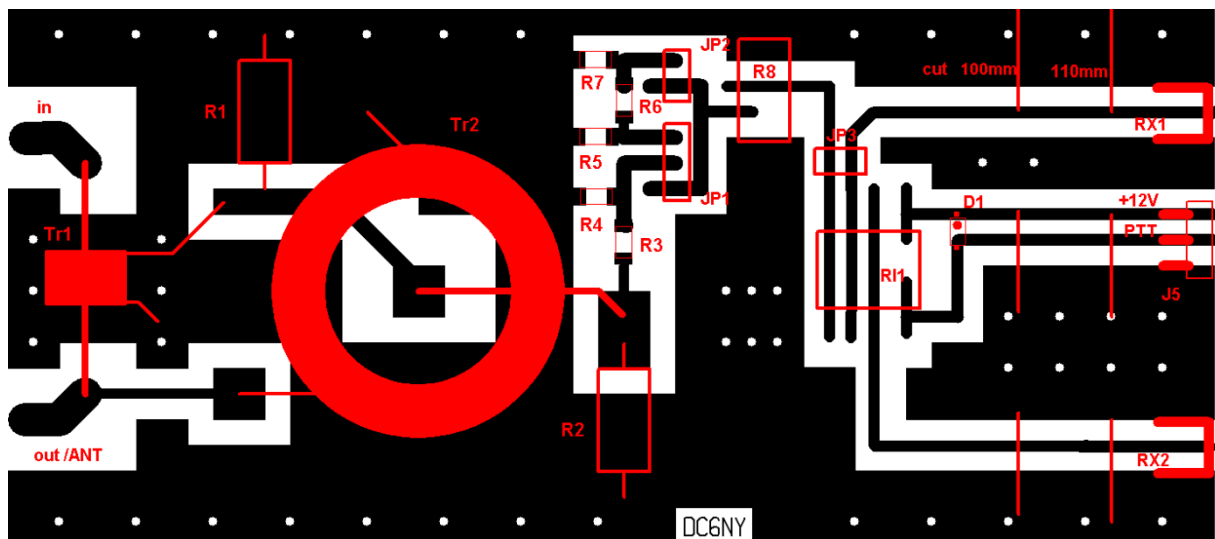

Figure 2 - PCB

The board will fit into at least three standard aluminum profile closures like Hammond, Fischer electronic or an inexpensive Chinese product – shipped worldwide by RF Suppliers Ltd. The length of the board (100 ... 120 mm) can be cut at one end according to the used enclosure. The Gerber data are available.

Due to a power level up to 1.5 kW the ports J1 and J2 should be equipped with SO-239 or N-connectors. The small signal ports provide SMA sockets directly soldered on the PCB. Fig. 3 shows a possible suggestion for the complete assembly.

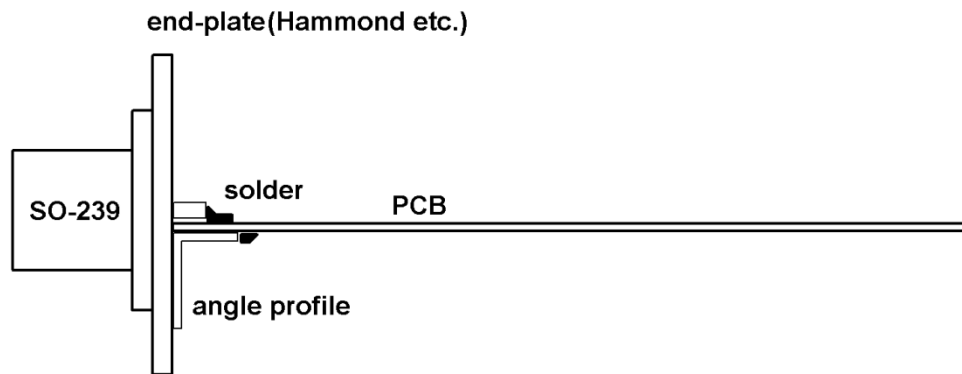

Figure 3 – Assembly PCB - endplates

Bill of material

D1	1N4148, SOD-323F
J1, J2	So-239 or N-connector
J3, J4	SMA socket, for PCB (vertical)
J5	Molex 3 pin SMD
Jp1	3 pin smd
Jp2, Jp3	2 pin smd
R1, R2	56R, 2 watts metal film
R3	330R, 1206
R4	56R,1206
R5, R7	100R, 1206
R6	68R, 1206
R8	5k0 trim, 0.1W, vertical
R11	FTR-B3SA 12V, FUJITSU
Tr1	sec. 31 windings 0.3 mm on Amidon FT-50-43 prim. 1 winding 1.5 mm Teflon coated wire
Tr2	sec. 31 windings 0.5 mm Prim. 1 winding 1.0 mm Teflon coated up 800W: Amidon FT82-61 up 1500W: Amidon FT114-61
pcb	1.5mm FR4, 0.35µm double-side

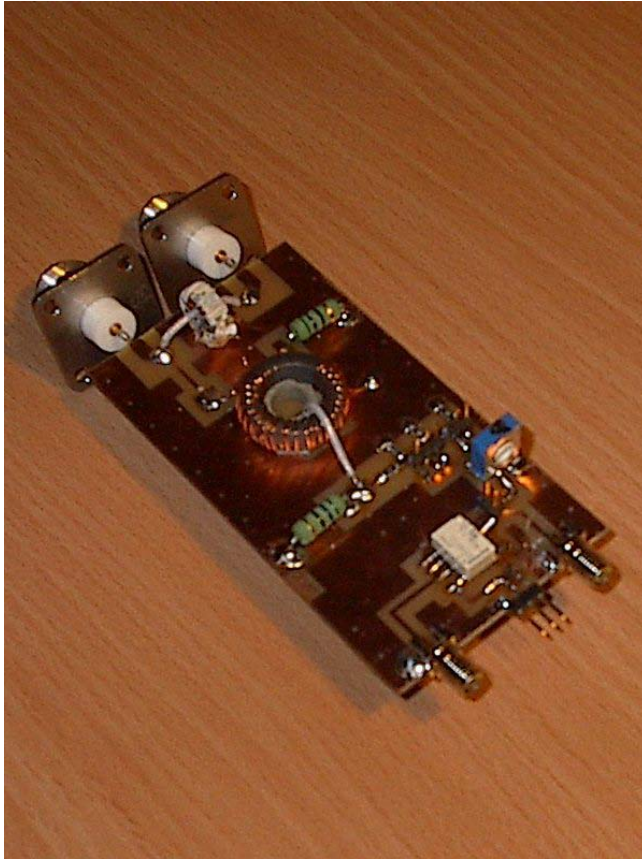

Figure 4 – Prototype RF sampler

A homebrew prototype of the board is shown in Figure 4. A Teflon washer should be applied below the toroids to keep windings in good distance of the copper surface.

Function test after assembling:

J1 connected to dummy or antenna. Set jumper JP3 to bypass the relay, set jumper JP1 at 1-2 and turn R8 to maximum.

Apply 1 W (+30 dBm) CW signal at J2. You should measure ~ -23 dBm at J4. If not, make sure that phasing of Tr2 is correct and you get the forward power signal.

Change the ends of the secondary winding if necessary.

Check also the second pad for > 100W TX power: set Jp1 2-3 and Jp2 4-5 and you will measure ~ -33 dBm with the 1W CW-test-signal.

Remove Jp3, apply relay control and you are ready to adjust the Rf sampler finally in the pre-distortion loop by means of R8.